

ITEM NO.	PART NUMBER	DESCRIPTION	QTY.	ITEM NO.	PART NUMBER	DESCRIPTION	QTY.
1	50818	PIN, TKO, MICRO	1	1	50898WS	BODY, SIGHT VENOM, W/SCALES	1
2	50655G	FIBER, TKO, MICRO, GREEN	1	2	50910	EXTENSION, ONE PEICE	1
				3	70279	FW .187 x .125 x .031 Brass (Blk)	3
1	50818	PIN, TKO, MICRO	1	4	50714WS	SLIDE,WINDAGE W/SCALES	1
2	50655R	FIBER, TKO, MICRO, RED	1	5	C-226G	PIN, TKO, MICRO, GREEN, ASSY	1
				6	C-226R	PIN, TKO, MICRO, RED, ASSY	1
1	50818	PIN, TKO, MICRO	1	7	C-226Y	PIN, TKO, MICRO, YELLOW, ASSY	1
2	50655Y	FIBER, TKO, MICRO, YELLOW	1	8	70410	SCREW, #4, 1/2 LG, PLASTITE	2
				9	70102	FHCS 10-24 X 5/8	2
				10	70264	LW #6 HI COLLAR	2
				11	70022	LW #4 Hi-Collar	3
				12	70172	SHCS 4-40 X 5/16	3
				13	70168	SHCS 6-32 X 7/8	1
				14	70212	SHCS 6-32 X 1/2	1
				15	52169BLK	GUARD, VENOM W/ LIGHT	1
				16	52300	DECAL, COBRA, 3/4" DIA	1
				17	52195	DECAL, RING, SCOPE, ORANGE	1
				18	20126	CARD, C-515	1
				19	20160	CLAMSHELL, NEW, MINI	1

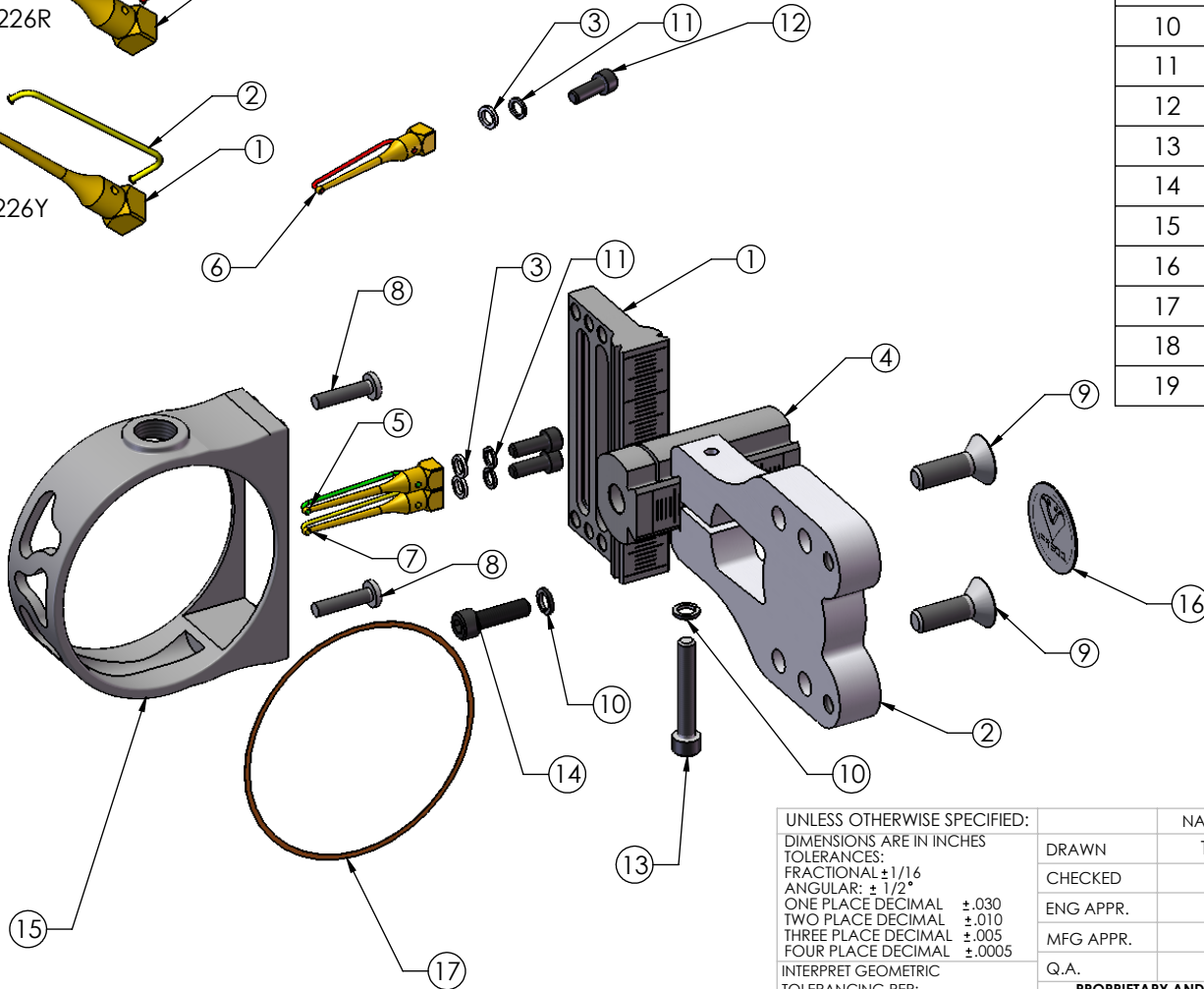

UNLESS OTHERWISE SPECIFIED:
 DIMENSIONS ARE IN INCHES
 TOLERANCES:
 FRACTIONAL ±1/16
 ANGULAR: ± 1/2°
 ONE PLACE DECIMAL ±.030
 TWO PLACE DECIMAL ±.010
 THREE PLACE DECIMAL ±.005
 FOUR PLACE DECIMAL ±.0005
 INTERPRET GEOMETRIC TOLERANCING PER:
 MATERIAL
 SEE COMPONENT PART
 FINISH
 SEE COMPONENT PART
 DO NOT SCALE DRAWING

	NAME	DATE
DRAWN	TS	8/7/09
CHECKED		
ENG APPR.		
MFG APPR.		
Q.A.		

PROPRIETARY AND CONFIDENTIAL
 THE INFORMATION CONTAINED IN THIS DRAWING IS THE SOLE PROPERTY OF COBRA MANUFACTURING. ANY REPRODUCTION IN PART OR AS A WHOLE WITHOUT THE WRITTEN PERMISSION OF COBRA MANUFACTURING IS PROHIBITED.

NOTE: DEBURR & BREAK ALL SHARP EDGES.
 COBRA MANUFACTURING CO., INC
 BIXBY, OKLAHOMA

TITLE:
MINI VENOM

SIZE A	DWG. NO. C-515	REV -
------------------	--------------------------	----------

SCALE: 1:4 WEIGHT: 0.24 SHEET 1 OF 1